







## RATED LIFTING CAPACITIES (IN POUNDS)

Load Radius (ft.)	27.3 ft. Boom 			46 ft. Boom 			62 ft. Boom 			78 ft. Boom 			94 ft. Boom 		110 ft. Boom 		
	Loaded Boom Angle	Outriggers Extended			Loaded Boom Angle	Outriggers Extended			Loaded Boom Angle	Outriggers Extended		Loaded Boom Angle	Outriggers Extended	Loaded Boom Angle	Outriggers Extended		
		Max.	Mid.	Min.		Max.	Mid.	Min.		Max.	Mid.		Max.		Max.		
5	79°	40,000	28,000	20,000													
8	73°	26,000	26,000	15,000													
10	68°	21,800	21,800	10,150	78°	18,000	18,000	9,600									
12	63°	19,000	19,000	7,300	76°	18,000	18,000	7,100									
14	58°	16,600	16,450	5,550	73°	16,000	16,000	5,500	78°	14,400	14,400						
16	53°	14,600	12,550	4,350	70°	14,200	12,600	4,400	76°	13,000	12,000						
20	41°	11,400	8,150	2,700	65°	11,200	8,400	2,900	73°	10,400	8,000	77°	9,500	8,300	80°	5,300	
25	17°	7,900	5,200	1,450	58°	8,800	5,600	1,850	68°	8,000	5,600	73°	7,550	5,650	77°	5,300	
30					49°	6,800	3,950	1,100	62°	6,300	4,050	69°	6,100	4,050	74°	5,300	
35					40°	5,200	2,850	500	57°	5,300	2,950	65°	5,100	3,000	70°	5,000	
40					28°	4,000	2,050		51°	4,400	2,200	61°	4,500	2,250	67°	4,300	
45									44°	3,600	1,600	56°	3,700	1,700	64°	3,700	
50									37°	2,900	1,150	52°	3,100	1,250	60°	3,150	
55									27°	2,300		47°	2,550	900	56°	2,650	
60									10°	1,600		41°	2,100	600	52°	2,150	
65												35°	1,700		48°	1,800	
70												27°	1,300		44°	1,450	
75												14°	850		39°	1,150	
80															33°	850	
85															26°	600	
90																38°	450
	0°	5,800	4,800	1,250	0°	2,200	1,450		0°	600							
		(25.85ft.)				(44.52ft.)				(60.52ft.)							

NOTE :

1. Rated lifting capacities on this chart show maximum allowable loads with all outriggers and stabilizers properly extended on a firm surface and the crane leveled and mounted on a factory recommended truck. The rated lifting capacities in shaded areas are based on crane strength and others, on its stability (not to exceed 85% of tipping).
2. The weight of handling devices such as hook block, slings, etc., must be considered part of the load and must be deducted from the rated lifting capacities.
3. Weights of any accessories attached to the boom or loadline must be deducted from the rated lifting capacities.
4. The operator must reduce loads to allow for such factors as wind, ground conditions, operating speed and the effects of freely suspended loads such as boom deflection.
5. For full capacity 360° around the truck, the chassis requires the front stabilizer and additional counterweight in the underside of the bed.
6. When making lifts at a load radius not shown, use next longer radius to determine allowable capacity.  
When boom length is between values listed, refer to rated lifting capacities of next longer and next shorter booms for same radius. Lesser of the two rated lifting capacities be used.
7. Max. outriggers extended means, as shown below, both outriggers and both rear stabilizers fully extended to the Max. position are properly jacked up.  
Mid. outriggers extended means, both outriggers extended to the Max. and both rear stabilizers extended to the Min. are properly jacked up, or otherwise, both outriggers extended to the Mid. and both rear stabilizers extended to the Max. or Min. are properly jacked up.  
Min. outriggers extended means, both outriggers extended to the Min. and both rear stabilizers extended to the Max. or Min. are properly jacked up.
8. For boom lengths longer than 46 ft., extend outriggers to the Max. or Mid. extended.  
For boom lengths longer than 78 ft., extend outriggers to the Max. extended.
9. 46 ft. boom means 1st     mark on 2nd boom section side plate is half visible.  
62 ft. boom means 2nd     mark on 2nd boom section side plate is half visible.  
78 ft. boom means 3rd     mark on 2nd boom section side plate is half visible.  
94 ft. boom means 4th     mark on 2nd boom section side plate is half visible.
10. Winch wire rope: diameter × length 9/16" × 315', breaking strength 30,100 lbs.

11. Keep at least 3 wraps of loadline on winch drum.
12. Maximum load for number of part lines is as shown below.
13. Rated lifting capacities depends on outriggers and rear stabilizers extended width.

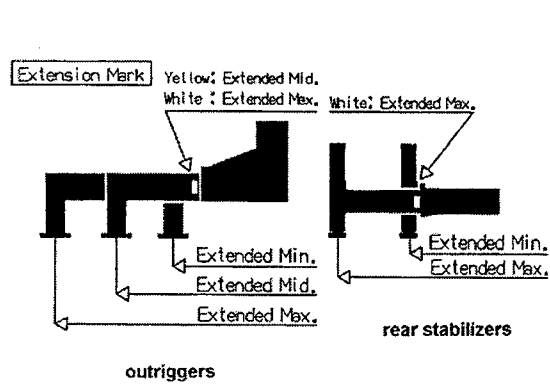

No. of part lines	1	2	4	6
Max. of load	7,200lbs.	14,400lbs.	28,800lbs.	40,000lbs.

# WORKING RANGE CHART

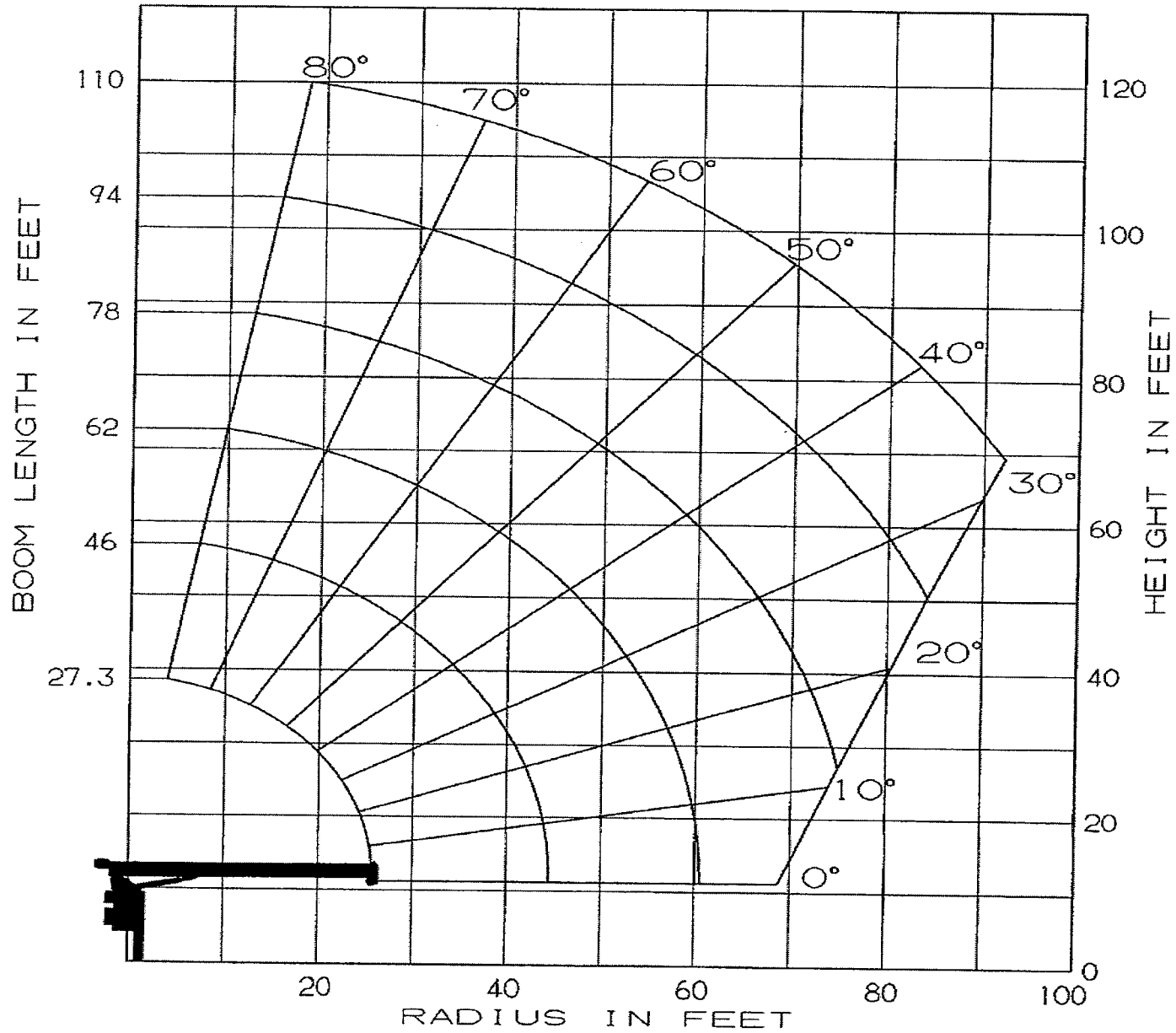

Note: The above lifting heights and boom angles are based on a straight (unladen) boom, and allowance should be made for boom deflection obtained under laden condition.

## TRUCK CHASSIS DATA (TRUCK MOUNT)

**Recommended requirements for TM-20110, full capacity 360° around the truck.**

This mount requires front stabilizer, rear stabilizers, torsion resisting box and additional counterweight in the underside of the bed for full capacity 360° around the truck.

Gross Axle Weight Rating(GAWR),front	approx. 16,000 lbs
Gross Axle Weight Rating(GAWR),rear	approx. 34,000 lbs
Gross Vehicle Weight Rating	approx. 50,000 lbs
Wheelbase(WB)	232" to 260"
Cab to axle	160" to 190"
Stability weight, front	8,500 lbs Min (*)
Stability weight, rear	9,500 lbs Min (*)
Frame Section Modulus(SM) under crane, front spring hunger of front spring to rear spring hunger of rear spring 110,000 PSI steel	20 in <sup>3</sup> Min. per rail
Frame Section Modulus(SM) at the front stabilizer attachment point, 110,000 PSI steel	2 in <sup>3</sup> Min. per rail
Frame Section Modulus(SM) over rear stabilizers, 110,000 PSI steel	13 in <sup>3</sup> Min. per rail
PTO torque	Approx. 290 ft-lbs Min.
PTO revolution	Approx. 550 to 2,400 rpm.
Width for crane mounting	Approx. 4'7"Min.
Frame width (outside)	Approx. 3' Max.
Frame height (ground to frame top)	Approx. 3'6"Max. (Height of crane mounting base can be changed by combination of jack floats and crane bases)

(\*)Estimated axle scale weights prior to installation of crane, stabilizers and torsion resisting box for 85% stability. Include counterweight.

The complete unit must be installed in accordance with factory requirements and a test performed to determine actual stability and counterweight requirements since individual truck chassis vary.

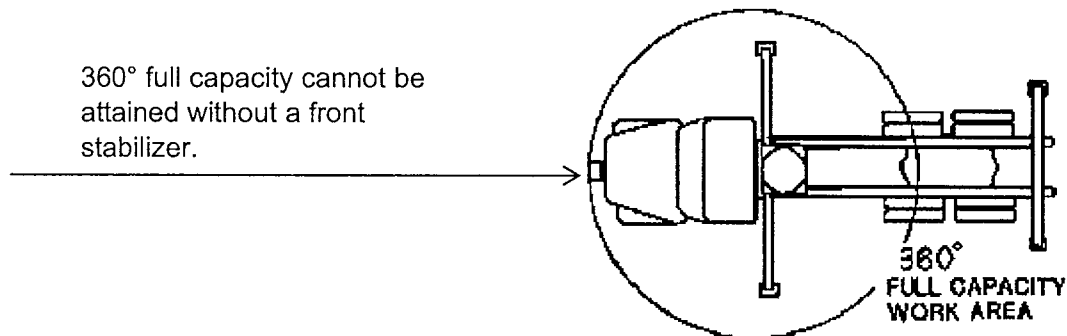

**TM20110 Mounting image with 22ft bed**

